

Fisa tehnica

Panouri termoizolante

TECNO WALL

TecnoWall este un sistem de panouri izolate cu poliuretan expandat de inalta densitate, ideal pentru imbracarea peretilor perimetrali, folosit in constructiile civile si industriile. Partea exterioara a panoului TecnoWALL este din otel prevopsit microcutat, iar partea interioara din otel prevopsit nervurat fin sau neted.

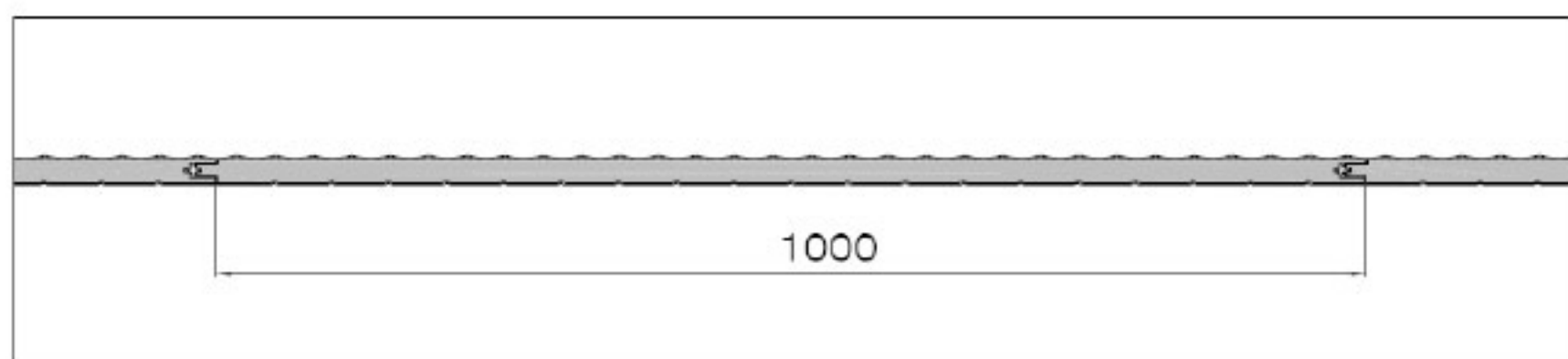

Versiunea 1.

- strat exterior: tabla otel prevopsit, $g=0,4$ mm microcutat
- strat median: spuma poliretanica, desitate 38-42 kg/m³
- strat interior: tabla otel prevopsit, $g=0,4$ mm nervuart fin

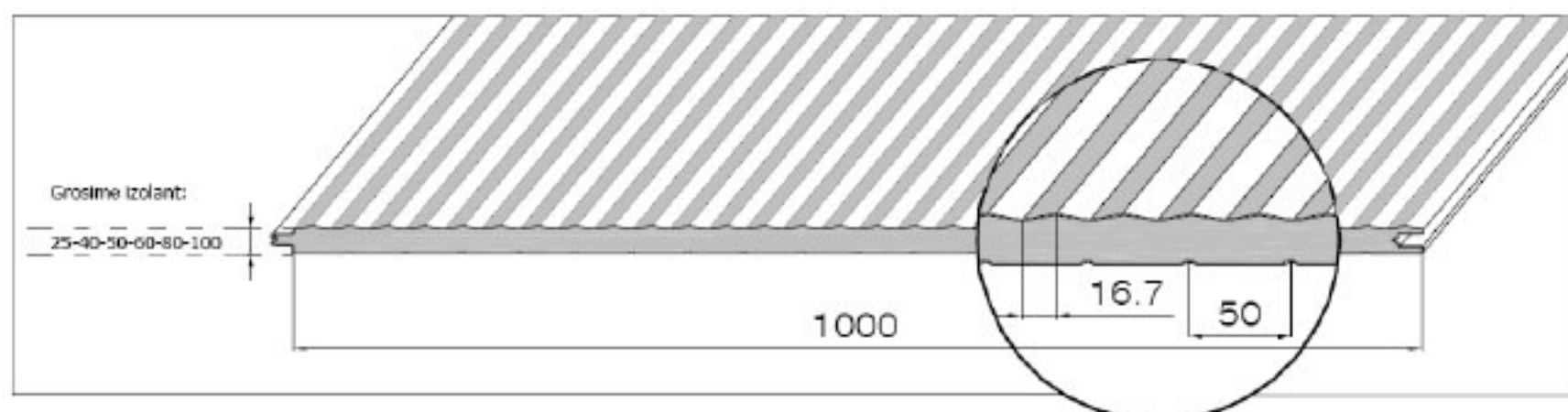

Grosime panou [mm]	Greutate [kg/m ²]	[W/m ² K]	[kcal/m ² h°C]	Capacitate portanta admisibila [kg/m]	
				Distanța între 1.5	reazeme [m] 2
25	7.82	0.80	0.67	221	157
40	8.42	0.48	0.41	196*	180*
50	8.82	0.39	0.33	217*	205*
60	9.22	0.33	0.28	250*	220*
80	10.02	0.27	0.21	280	250
100	10.82	0.23	0.17	300	275
150	12.70	0.14	0.12	485	345

*Date referitoare la panoul cu partea superioara si inferioara din otel prevopsit grosime 0.5 mm

Versiunea 2.

- strat exterior: tabla otel prevopsit, g=0,4 mm microcutat
- strat median: spuma poliuretana, desitate 38-42 kg/m³
- strat interior: tabla otel prevopsit, g=0,6 mm neted

